

Instructions for TPN Infusion Using a CADD Solis[®] Pump

Supplies Needed for Infusion

- ✓ TPN bag (remove from refrigerator one hour prior to infusing)
NOTE: Always check the label on your TPN bag to make sure the patient name is correct.
- ✓ Ordered additives:
 - Famotidine:**
Draw up _____ ml, add to TPN bag
 - Multi-vitamin (MVI):**
Draw up _____ ml, add to TPN bag
 - Insulin:**
Draw up _____ units, add to TPN bag
 - Other:** _____
Draw up _____, add to TPN bag
- ✓ Syringes and needles to draw up additives
- ✓ Two (2) Prefilled sodium chloride (0.9% Normal Saline) syringes
- ✓ One (1) Prefilled Heparin syringe (if applicable)
- ✓ Alcohol or antiseptic wipes
- ✓ CADD Solis[®] tubing
- ✓ CADD Solis[®] pump
- ✓ Four (4) AA batteries or a rechargeable battery pack and AC power adapter

Training Video Available!

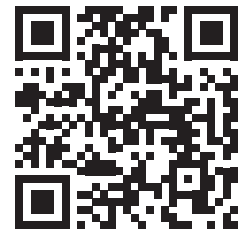

Scan the QR code using the camera on your smart phone or tablet to watch a quick instructional video.

Instructions for TPN Infusion Using a CADD Solis[®] Pump

Start Infusion

1. Clean work area. Wash hands thoroughly. Gather supplies.
2. Prepare your additives that have been ordered by your physician and add to your TPN bag as instructed by your nurse. Refer to the teaching guide "Adding Additives to your TPN or Hydration".
NOTE: Be sure to review the TPN label to determine what (if any) additives should be added to the bag.
3. Prepare your prefilled syringes for flushing your IV Catheter as instructed by your nurse.
4. Press and hold the Power button on the right side of pump (gray button on right side of pump). When the pump powers on, it performs various self tests. When the self tests are complete, the pump will beep six (6) times. The screen will display the pump mode showing "Ready to Begin" in center of screen.
5. Remove CADD Solis[®] tubing from package. Remove the blue clip from the top of the cassette by pulling up on the blue clip.
6. Remove protective tab from entry port of medication bag.
7. Remove the cover from the spike on tubing and insert spike into medication bag using a pushing-twisting motion. **Do not touch spike.**
8. Open cassette latch lever 90 degrees and attach new cassette to pump (hook hinged end first). Push up on cassette until it firmly clicks into place OR place the pump upright on a firm, flat surface and then pull up on the latch side of the pump until the cassette clicks into place.

Lift the cassette latch into the closed position.

NOTE: Do not force latch. If you are unable to latch the cassette with minimal to no resistance, the cassette is not in the proper latching position. Unlatch the cassette and repeat the process. Top of screen will flash "High Volume Administration Set Latched".

9. After cassette is attached, screen will display, "Prime Tubing?", select **YES** to prime the tubing now. Confirm that the tubing is disconnected from your catheter, open clamps, and select "Prime". You can stop priming at any time by selecting "Stop Priming". Priming automatically stops after 20 ml are primed.
10. Check the pump screen, it will display a question, "Reset reservoir volume to __?" select **YES**, to reset the volume. If the pump screen does not display this message, then **OK** to press the "Start/Stop" button to start the infusion once you have completed flushing line and attaching the medication tubing.
11. Make sure all clamps are open on IV access line and scrub the injection cap on the end of your IV catheter with an alcohol/antiseptic wipe vigorously for 30 seconds and let air dry.
12. Attach a prefilled Sodium Chloride/Saline syringe to the injection cap of your IV catheter injection cap and flush with 10 ml using the push/pause method.

Instructions for TPN Infusion Using a CADD Solis[®] Pump

Start Infusion (continued)

13. Disconnect the syringe from the injection cap of your IV catheter and discard.
14. It is not necessary to scrub injection cap with alcohol swab again unless the end cap comes in contact with a surface or touches skin.
15. Remove the protective cap from the end of the CADD tubing and attach tubing to the injection cap on the end of your IV catheter. **Do NOT touch the end of the tubing.**
16. To start the pump, press the stop/start button on the keypad. Then **"Start Pump?"** appears, select **YES**. The pump will display that it is running and the green indicator light will flash.

***NOTE:** After a short time, the display turns itself off to save power, but the green light will continue blinking to indicate the pump is running. To reactivate display screen, press any button on the keypad.*

Stop Infusion

17. When the infusion is completed, the pump will alarm and say **"Reservoir Volume is ZERO-Pump Stopped"**. Press **"Acknowledge"** to stop the alarm.
18. Close the clamp on the pump tubing. Disconnect IV tubing from IV catheter. Cleanse injection cap with alcohol for 30 seconds and allow to dry, then flush with Sodium Chloride/Saline syringe as directed by your nurse.
19. Cleanse injection cap with alcohol for 30 seconds, and allow to dry, then flush with Heparin (if applicable) as directed by your nurse.
20. Turn pump off by pressing the Power button **OR if hooking up a new bag, repeat steps 1-16.**

***NOTE:** If pump does not prompt you to **Reset Reservoir Volume**, go to **Tasks** menu, press the up and down arrows on the keypad to highlight **Reset Reservoir Volume** and press **Select**. The pump displays a question asking if you wish to reset the Reservoir Volume to the default amount for your therapy. Select **"YES"** to reset the volume.*

NOTE: All syringes with needles and glass vials should be disposed of in your sharps container. All remaining used supplies and waste can be bagged and disposed of in your household garbage.

SASH TEACHING GUIDE

S

Saline

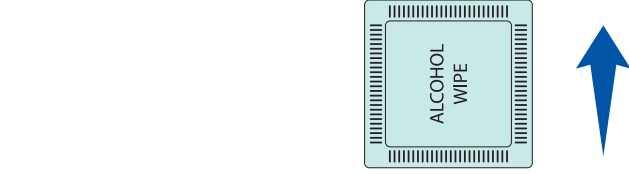

A

Administration
of Medicine

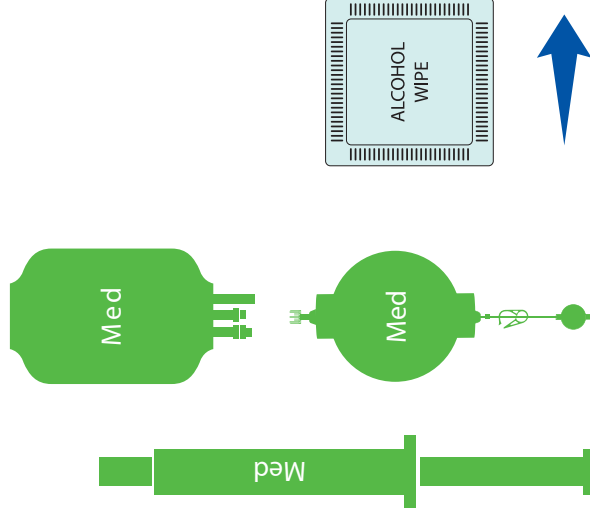

S

Saline

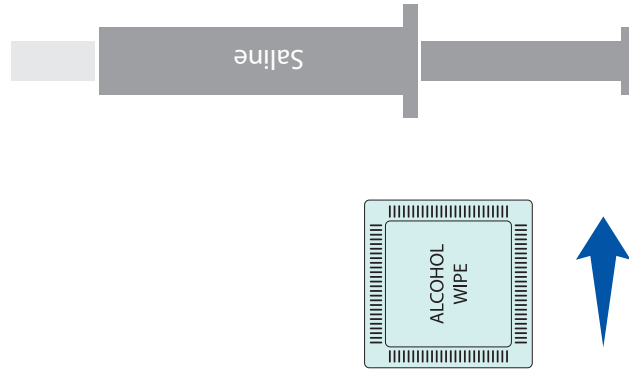

H

Heparin
(if ordered)

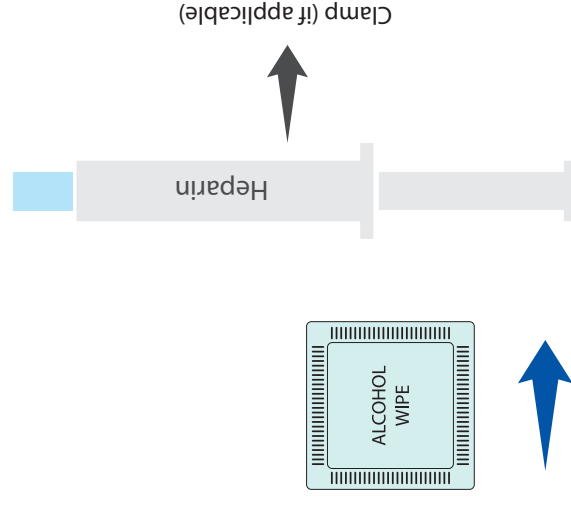

REMEMBER TO

- Use a new alcohol wipe for each step and scrub for at least 30 seconds.
- Clean your hands thoroughly using antibacterial soap and warm water. If no soap and water is available, use an alcohol-based hand sanitizer.
- If required, remove medication from refrigerator prior to use. Refer to medication label for required time.